

## 123\SmartRelay manual

Rev 4



## Introduction

123\SmartRelay is a dual relay module with extremely low self-power consumption. It can be used to switch high currents or even small signals. The design ensures long operation, even on very small batteries. It is a perfect companion with the 123\SmartBMS if you need to switch inverters and/or chargers.

### Smart

An integrated microcontroller ensures reliable operation in harsh environments, combined with very low power consumption. Two LEDs display the current state of each relay. One flash means the relay is off, two flashes indicate the relay is on. It's as simple as that.

## Electrical specifications

| Description                             | Value / range |        |
|---|---------------|--------|
| Operating supply voltage range          | 9.0V to 70.0V |        |
| Operating temperature range             | -40 to 70°C   |        |
| Maximum current consumption average     | @12V          | <0.3mA |
|   | @24V          | <0.4mA |
| Minimum signal input voltage to turn on | 5V            |        |
| Maximum switching current               | @12VDC        | 120A   |
|   | @24VDC        | 100A   |
|   | @230VAC       | 120A   |
| Maximum switching time                  | 0.3s          |        |

## Mechanical dimensions

| Description  | Value               |
|--|---------------------|
| Total dimensions LxWxH (mm)                          | 62x63x80            |
| Relay terminal                                       | M6                  |
| Mounting bolt top                                    | M5                  |
| Mounting bolt bottom                                 | M4                  |
| Power supply and inputs max cable (mm <sup>2</sup> ) | 0.75mm <sup>2</sup> |

## Mounting

The module contains two long bolts and nuts to keep the module's relays in place. It is possible to mount the module by removing the nuts, drilling the respective two holes in the plate where the modules needs to be mounted and adding the nuts again behind the plate.

Another option is to remove one bolt and then insert the desired mounting bolt/screw. When done, remove the other bolt and replace this with the other desired mounting bolt/screw.

**Note: always make sure there is one bolt in the relay when changing the other. Otherwise the module will lose its strength.**

## Connecting the module

First make sure the module is powered by connecting pin 1 of the connector to the negative pole of the power supply like a battery pack. Now connect pin 4 of the connector to the positive pole of the power supply. The system is functional.

As soon as a signal like the positive of the power supply is applied to input 1 (pin 2 of the connector), relay 1 turns on. When the signal is removed, the relay turns off. Relay 2 behaves the same. By applying a signal to input2, relay 2 turns on. Removing the signal turns relay 2 off.

## Example schematics with 123\SmartBMS

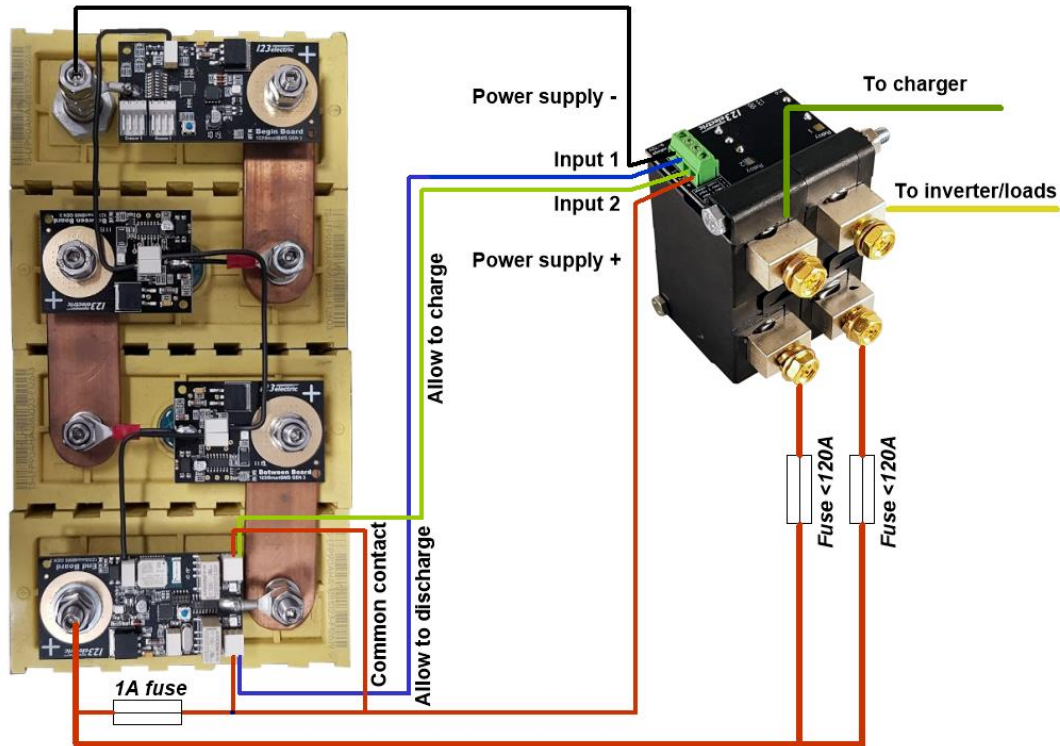

Figure 1 - 123\SmartBMS example with inverter and charger

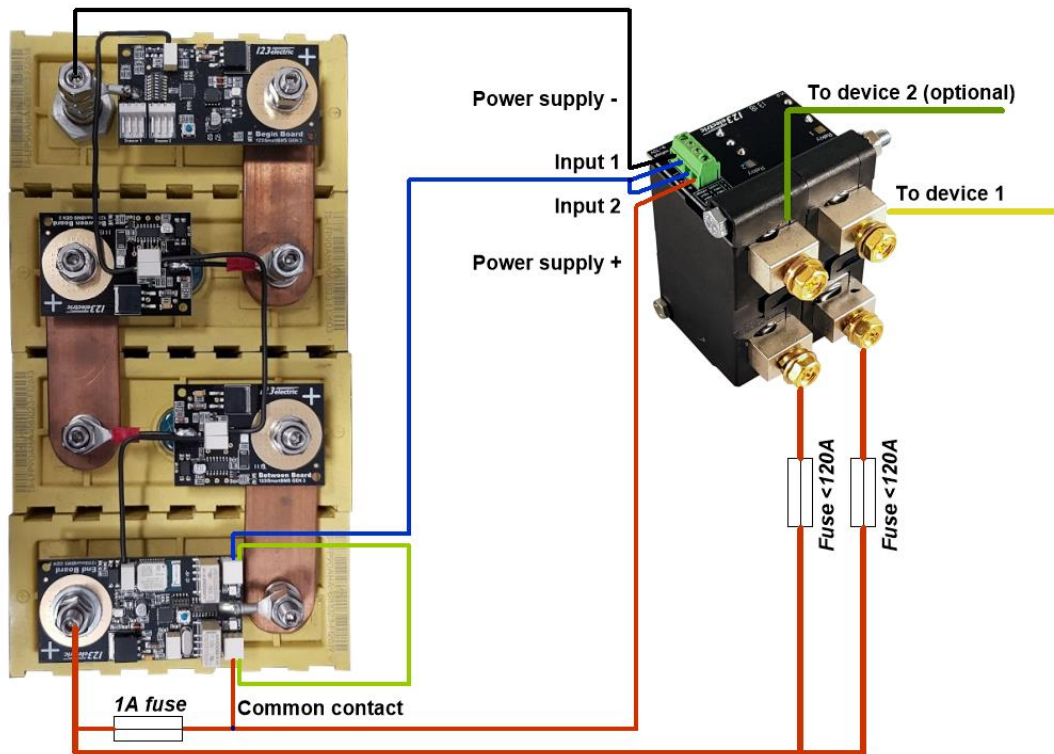

Figure 2 - 123\SmartBMS configured in Critical Mode with combined charger/inverter in 1 device

## Splitting up loads

Each relay can switch up to 120A depending on the voltage of the load. If the total current exceeds this 120A, it may be possible to split up the load in multiple smaller loads. If it is possible to split up the load into smaller <120A loads, both relays on the SmartRelay or even multiple SmartRelays can be used.

### Example

An application has a nominal voltage of 12V, the total load is 150A. Connected are two inverters, both 75A. One inverter is used for the sockets, water kettle and lightning, the other inverter for the water heater (900W).

Connect input1 to input2 of the SmartRelay. Relay 2 will now always be in the same state as relay 1. Relay 1 can be used to switch the power of inverter 1, relay 2 can be used to inverter 2.

**Do not connect both poles of relay1 to the poles of relay2 trying to “increase the maximum current”. Contacts in relays will never close at exactly the same time. Thus the total current will always be switched on or off in one relay.**

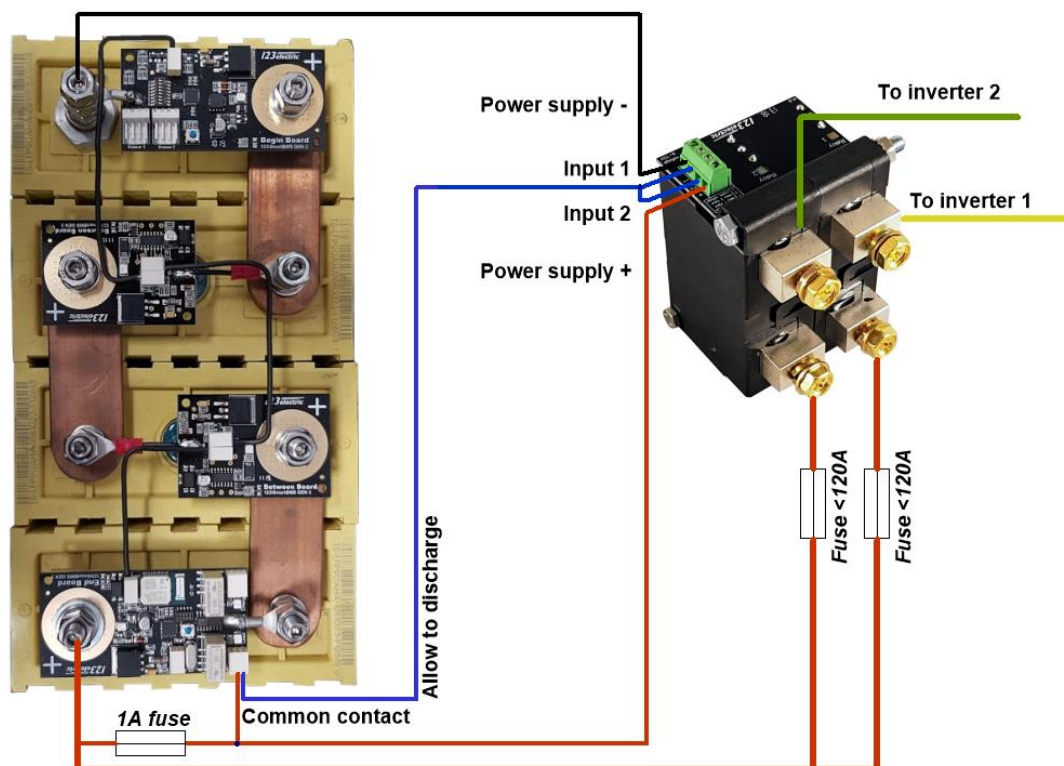

Figure 3 - 123\SmartBMS with splitted loads